

AT&T Standard Plant Training Course

Job Aid

PTC No.315
N1, N2, Carrier

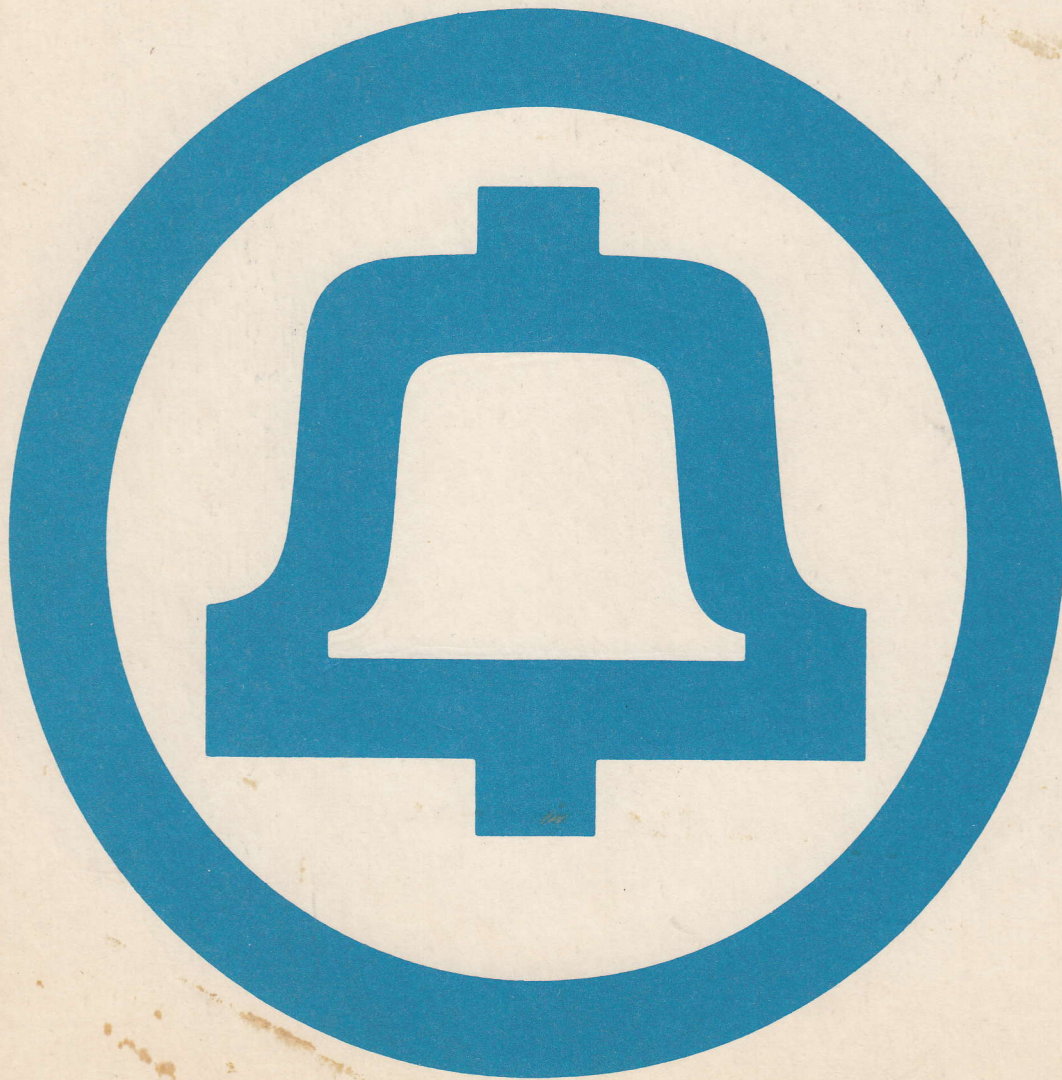

AT&T Standard Plant Training Course

Job Aid

Issue 1; June 1975

PTC No. 315

N1, N2, Carrier



ACKNOWLEDGMENTS

Portions of this Job Aid were developed by the following companies:

New England Bell Telephone Company

AT&T Long Lines (Southern Area)

New Jersey Bell Telephone Company

Southwestern Bell Telephone Company

Southwestern Bell Telephone Company
American Telephone & Telegraph Company

Notice: This material is prepared for Bell System purposes and is for the use of Bell System employees only. Its distribution is in no sense a publication. Neither the material nor any portion thereof is to be reproduced in any form without the written permission of the American Telephone and Telegraph Company.

"COMP" POT ADJ. TO +8dBm AT T.P. "F"

"REL CUP" POT, ADJ TO 15 VOLTS WHILE OBSERVING METER CONNECTED TO TP1 & 2 (DISTANT TERM MUST HAVE ON HOOK TOWARD YOU.)

LEFT SIDE

"MOD" POT, ADJ T.P. "M2" TO READING RECORDED ON FORM E4559

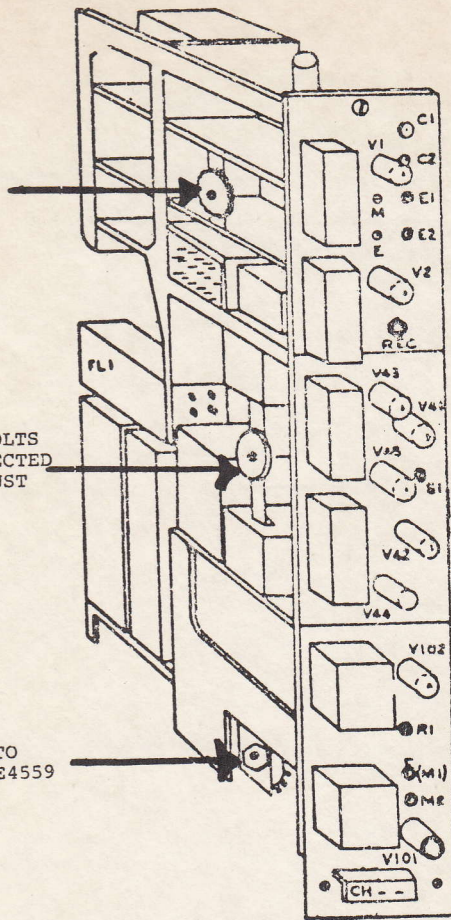

JOB AID - N1 CXR

Test Points, Test Levels, Electron Tubes and Their Functions.

"BRK" PCT ON TYPE "E" UNITS (ONLY).

"BRK" POT ADJ BIAS OF K41. DISTANT END SENDS 12PPS @ 58% BREAK MEASURING PULSES WITH 28 SIG TST SET ADJ POT UNTIL TST SET READS 62% BREAK. INITIAL READING SHOULD BE BETWEEN 56 & 64

TP1 (POSITIVE LEAD)

SHOULD READ 14-16 VOLTS

TP2 (NEGATIVE LEAD)

"SIG" POT - CONTROLS THE GAIN OF THE SIGNAL TONE AMPLIFIER (SEE NOTE 1)

"EXP" POT ADJ "E1-E2" TO +20dBm

TP3 - ENABLES SHUNTING DOWN THE OUTPUT LEVEL OF FILTER (3700 HZ) AS REQ IN CERTAIN LINE-UP TESTS. NO MEASUREMENTS ARE MADE FROM THIS POINT. TP3 IS A BARE PIECE OF WIRE.

"RED" POT ADJ "R1" TO READ -33dBm

Complete test and adjustment procedures may be found in the 362 Division of the Bell System Practice's.

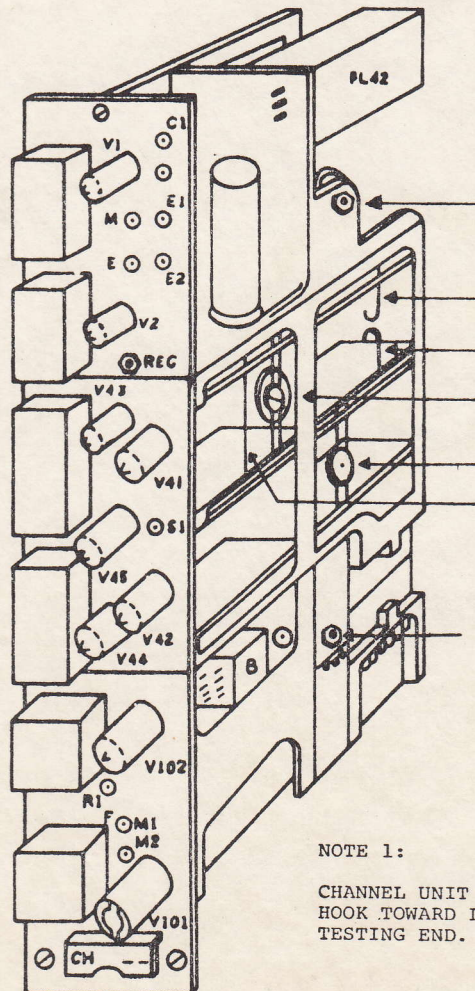

NOTE 1:

CHANNEL UNIT IN TEST STAND, HAVE DISTANT END PUT AN "ON" HOOK TOWARD LINE (M LEAD). THEN STRAP S1 TO TP3 AT TESTING END. A 2B SIG TST SET REQUIRED AT BOTH ENDS.

RIGHT SIDE

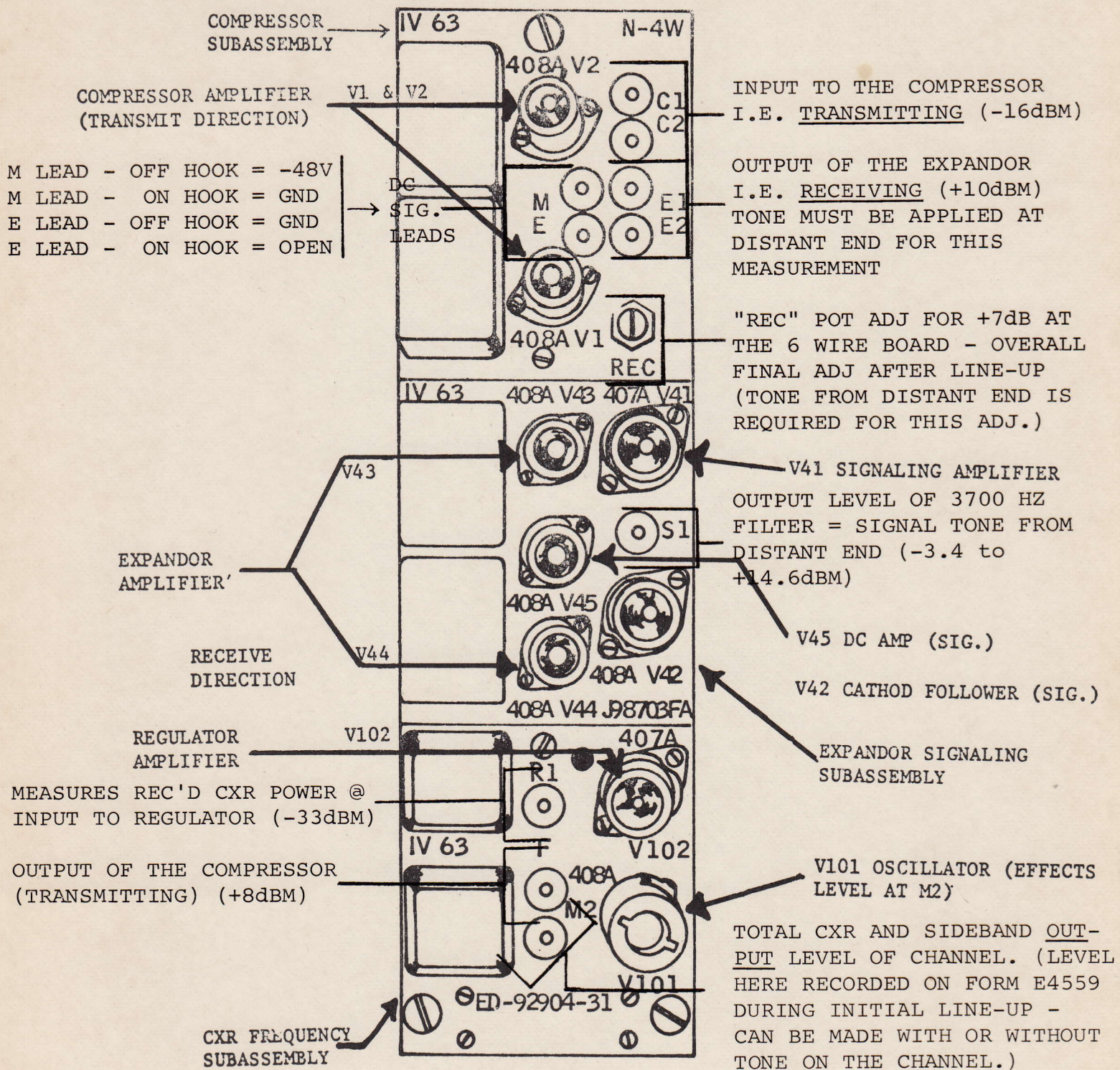

(1) N1 CARRIER CHANNEL

N1 CARRIER

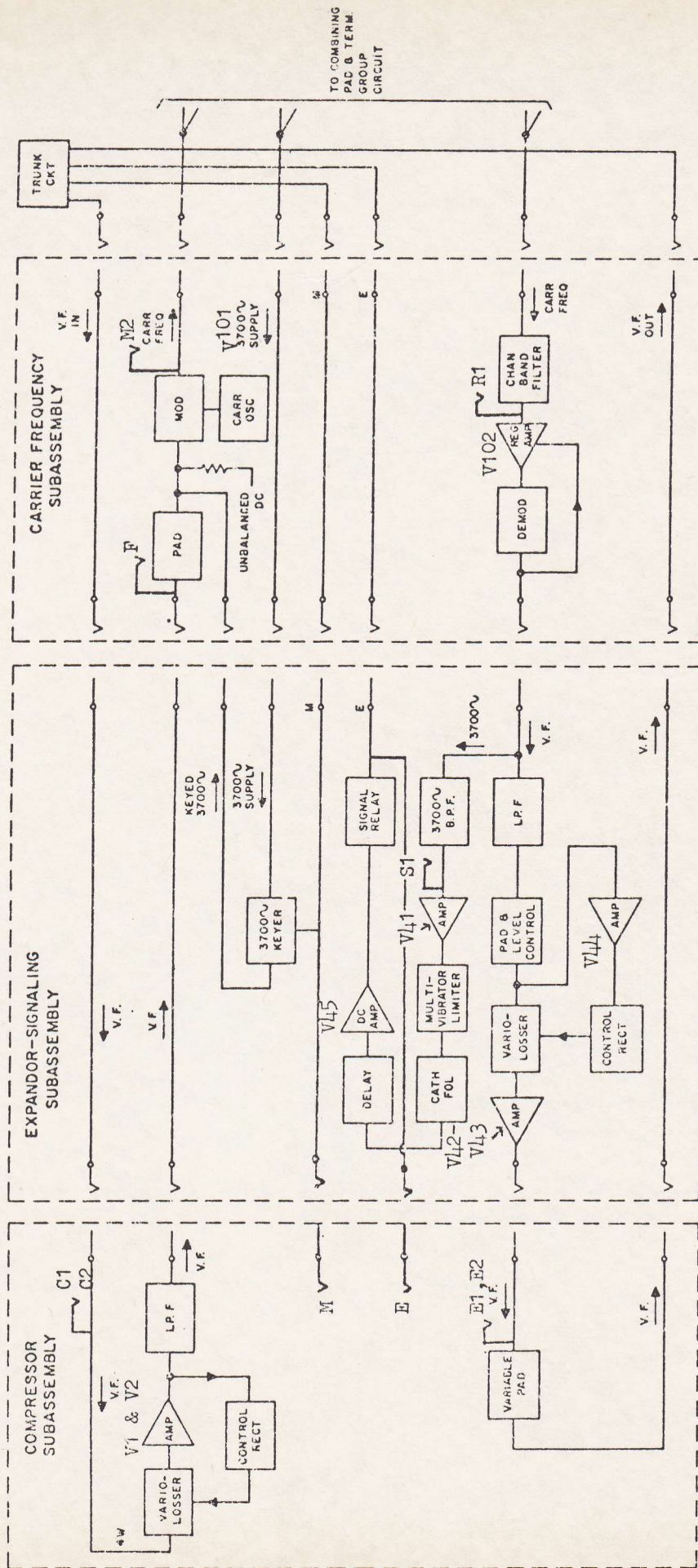

Channel Unit, Block Diagram

LINE-UP AND MAINTENANCE TESTS FOR N1 CARRIER MESSAGE CHANNELS (TYPE J98703F AND FA UNITS)

TEST	PURPOSE OF TEST	TEST STAND REC	MEAS. EQUIP. REQUIRED		MEASURE TEST POINT TO GRD. OR BETWEEN TEST POINTS	REQUIRED VALUE		ADJUST	TEST CONDITIONS AND REMARKS	SECTION REFERENCE
			TESTING END	DISTANT END		TEST	READJUST			
1	Channel Carrier Output	No	400C or D	—	M2	Recorded Value ± 0.5 db	Recorded Value	MOD	FA unit maintenance only. For F units and initial line-up see 362-025-501.	362-025-501
2	Channel Carrier Leak	No	400C or D; 2B Sig. Set	—	M2	At least 18 db below TEST 1	—	—	F Units Ground TP7, OFF HOOK on M lead	362-025-502
		No	400C or D	—	F	At least +8.5 db +7.5 to +8.5 db Max. —19.0 db	+8.0 db	COMP	COMP pot. at max. output. Send 1000 ~ at VF IN —16 dbm (4W); 0 dbm (2W).	
3	Compressor Noise	No	400C or D	—	F	At least +8.5 db +7.5 to +8.5 db Max. —19.0 db	+8.0 db	COMP	COMP pot. at max. output. Send 1000 ~ at VF IN —16 dbm (4W); 0 dbm (2W).	362-025-502
		No	400C or D	—	F	At least +8.5 db +7.5 to +8.5 db Max. —19.0 db	+8.0 db	COMP	COMP pot. at max. output. Send 1000 ~ at VF IN —16 dbm (4W); 0 dbm (2W).	
4	Received Channel Carrier	No	400C or D	—	R1	—13.0 to —29.0 db —28.0 to —38.0 db	—	REG	REG pot. set for maximum reading.	362-030-501
5	Demodulator Output	Yes	400C or D	—	Term. 6 of FL42 (188B)	+11.0 to +14.0 db	—	—	Distant End: Send 1000 ~ at 0 dbm (2W)	362-305-501
6	Expander Output	No	400C or D	1000 ~ Tone 2B Sig. Set	E1-E2	+8.5 to +11.5 dbm	+10.0 db	EXP	Testing End: For line-up turn REC max. cw. 600-ohm termination in MOD IN (2W), DEMOD OUT (4W.) —16 dbm (4W). OFF HOOK on M lead.	
7	Channel Regulation	Yes	400C or D	1000 ~ Tone 2B Sig. Set	R1	+9.0 to +10.5 db	—	REG	—	362-030-501
					E1-E2	—	—	—	—	
					R1	—	—33.0 db	—	REG	
8	Channel Noise	No	3A Noise Set	2B Sig. Set	MOD IN (2W) DEMODO OUT (4W)	See Section 362-305-510	—	—	Distant End: OFF HOOK on M lead, term. chan. in 600 ohms. Testing End: Turn REC extreme clockwise.	362-305-510
9	Channel Net Loss	No	Transmission Meas. Set	1000 ~ Tone 2B Sig. Set	MOD IN (2W) DEMODO OUT (4W)	2 Wire 4 Wire	Design Value +7.0 (+4.0)	REC	Distant End: OFF HOOK on M lead, send 1000 ~ 0 dbm (2W), —16 dbm (4W). Testing End: Set IDLE 2W channels to —10 dbm.	362-305-512
		Yes	400C or D	2B Sig. Set	S1	—3.4 to +14.6 db	—	—	Distant End: ON HOOK on M lead.	
10	Received Signal Level	Yes	400C or D	2B Sig. Set	TP1 to TP2 (+ to TP1)	14.0 to 16.0 Volts	15.0 V	REL CUR	—	362-305-515
11	Sig. Relay Current	Yes	Volt-ohm-meter	2B Sig. Set	Ec Jack of Test Stand	SIG. RELAY (K41) just operates as indicated by lamp on 2B Sig. Set	—	SIG	Testing End: Strap S1 to TP3. Turn SIG pot. max. cw, then cw slowly until L lamp on 2B sig. set just lights.	362-305-515
12	Sig. Receiver Sensitivity	Yes	2B Sig. Set	2B Sig. Set	SIG L Jack of Patch Bay, or Ec Jack of Test Stand	66 to 64%	62%	BRK	Distant End: Adjust 2B Sig. Test Set to send 12 PPS at 58% break.	
13	Per Cent Break	No	2B Sig. Set	2B Sig. Set	SIG L Jack of Patch Bay, or Ec Jack of Test Stand	Minimum 12%	—	—	Distant End: Send 12 PPS and adjust ADJ % BRK on 2B Sig Set slowly from extreme counterclockwise until a deflection just appears on 2B Sig. Set at testing end. Read % break at distant end.	362-305-515
14	Min. Length of Pulse	No	2B Sig. Set	2B Sig. Set	SIG L Jack of Patch Bay, or Ec Jack of Test Stand	Minimum 12%	—	—	Distant End: Send 12 PPS and adjust ADJ % BRK on 2B Sig Set slowly from extreme counterclockwise until a deflection just appears on 2B Sig. Set at testing end. Read % break at distant end.	362-305-515

N1 CARRIER

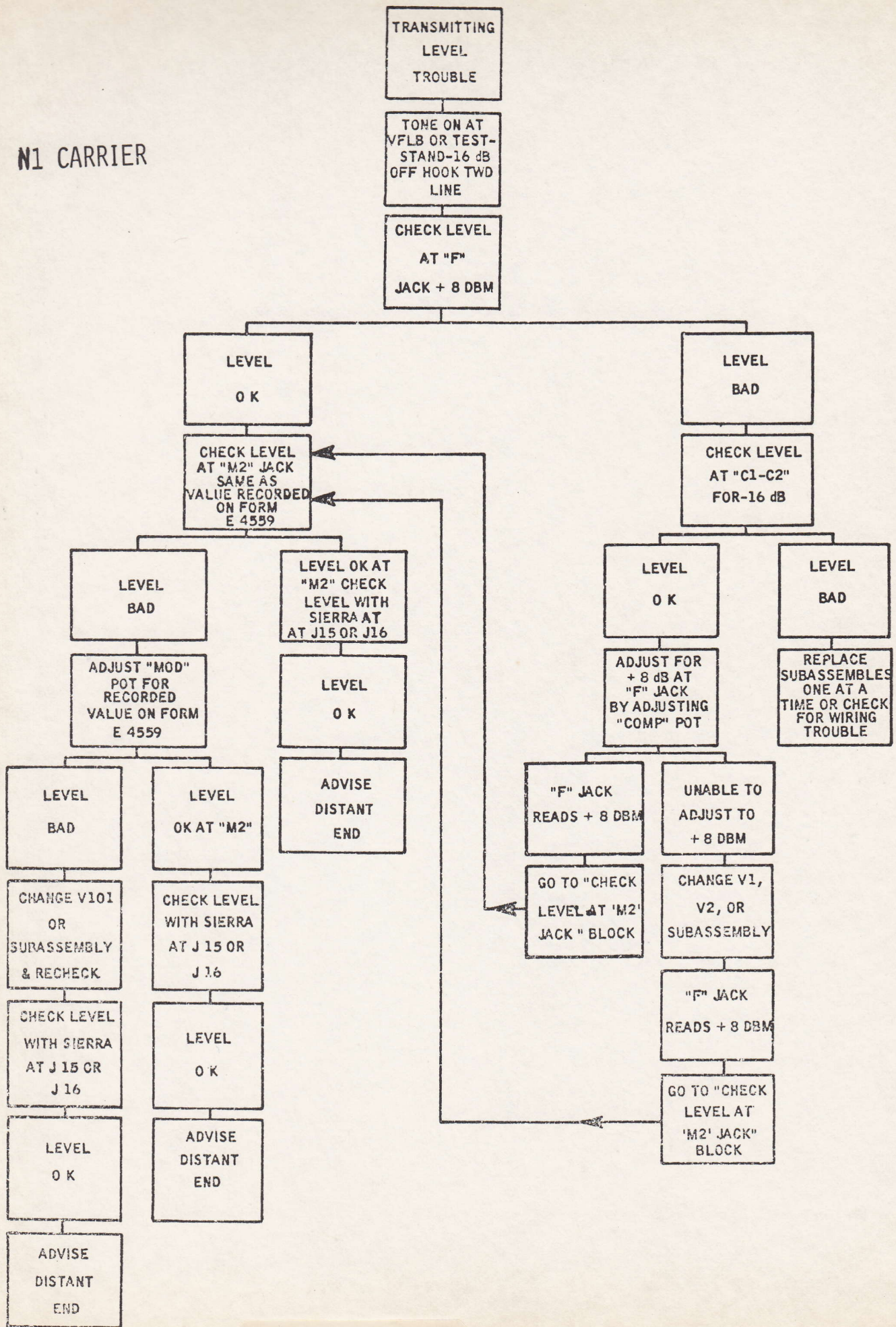

N1 CARRIER

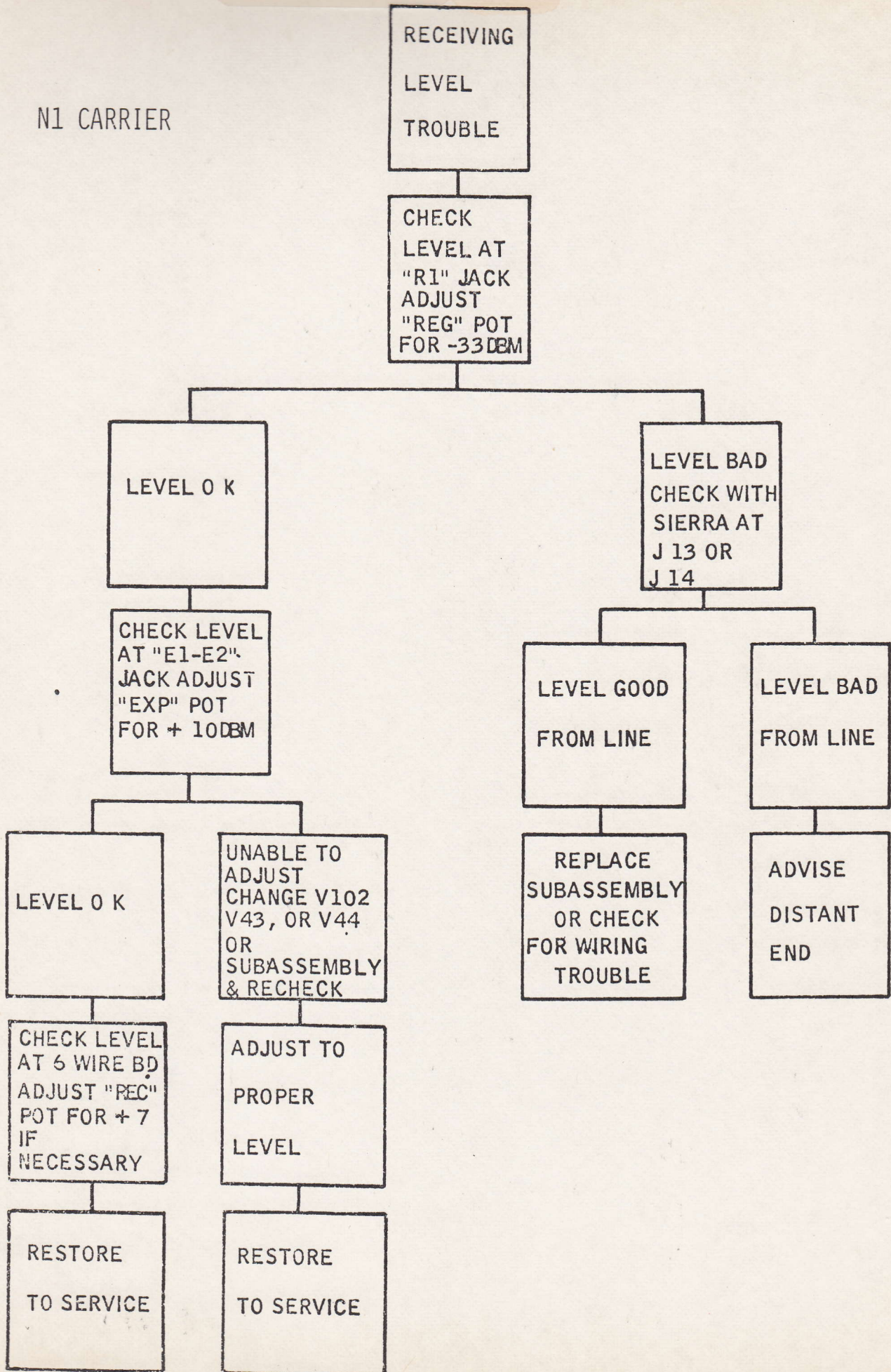

N1 CARRIER

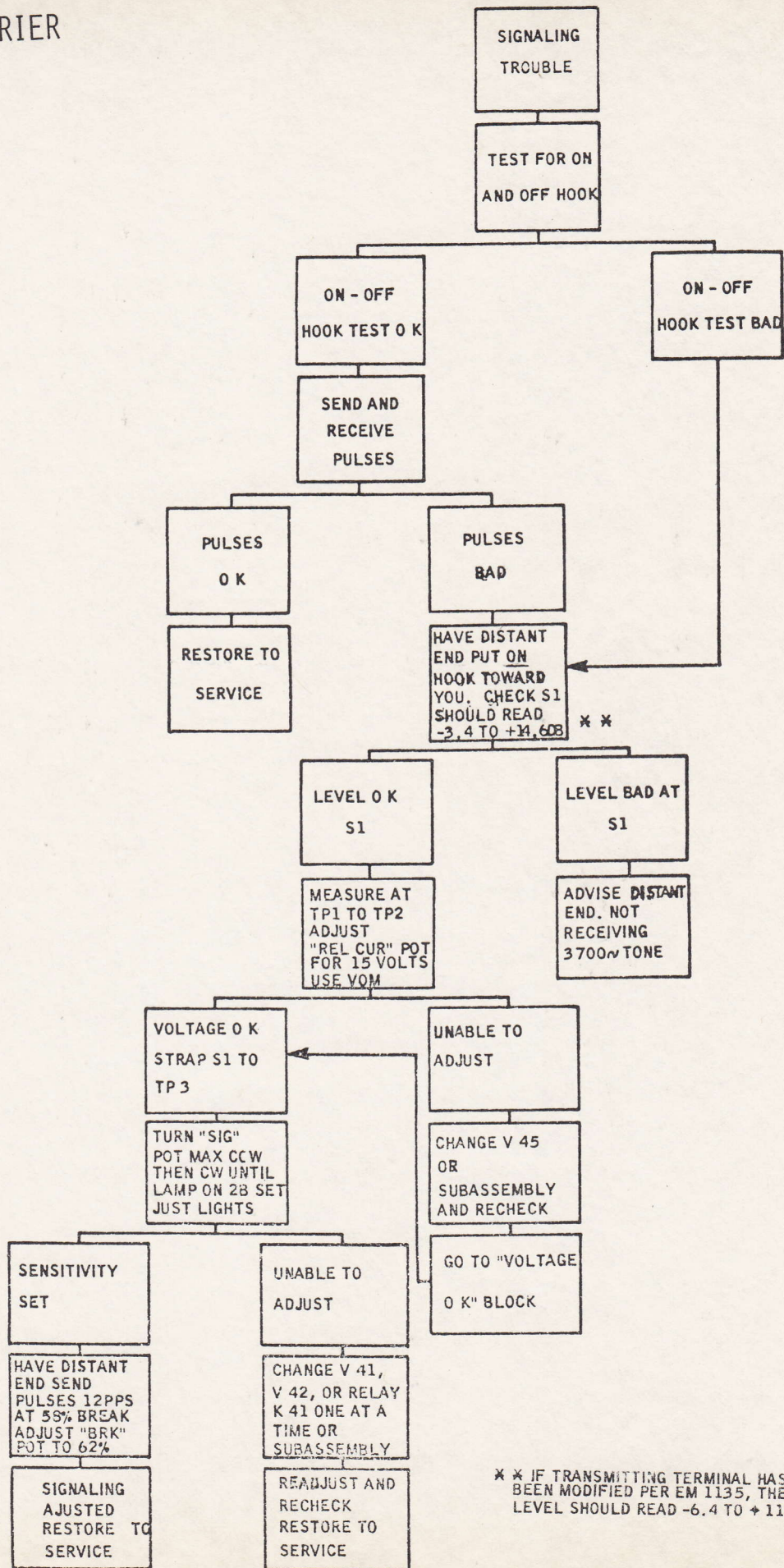

** IF TRANSMITTING TERMINAL HAS BEEN MODIFIED PER EM 1135, THE LEVEL SHOULD READ -6.4 TO +11.6db.

OPEN SYSTEM

RESTORE SERVICE BY PATCHING TO SPARE CHANNELS

OPEN TOWARD YOU

OPEN TO DISTANT END

SELECT CHANNEL SIERRA SELECTOR ON GR IN MEASURE AT J3 OR J4

CHECK LEVEL TRANSMITTING WITH 2J OR SIERRA AT J1 OR J2

LEVEL BAD

LEVEL GOOD AT GR IN

LEVEL GOOD

LEVEL BAD

HAVE 1ST ATTENDED STATION CHECK

BAD GROUP RECEIVE UNIT

HAVE 1ST ATTENDED STATION CHECK

REPLACE GROUP TRANSMIT UNIT

LEVEL GOOD TO 1ST STATION

LEVEL BAD TO 1ST STATION

LEVEL GOOD TO 1ST STATION

LEVEL BAD TO 1ST STATION

TROUBLE BETWEEN 1ST STATION AND YOU

TROUBLE BETWEEN 1ST STATION AND DISTANT END

TROUBLE LOCATES BETWEEN 1ST STATION AND DISTANT END

TROUBLE LOCATES BETWEEN YOU AND 1ST STATION

NOTIFY PROPER MAINTENANCE CENTER

NOTIFY PROPER MAINTENANCE CENTER

NOTIFY PROPER MAINTENANCE CENTER

NOTIFY PROPER MAINTENANCE CENTER

N1 CARRIER

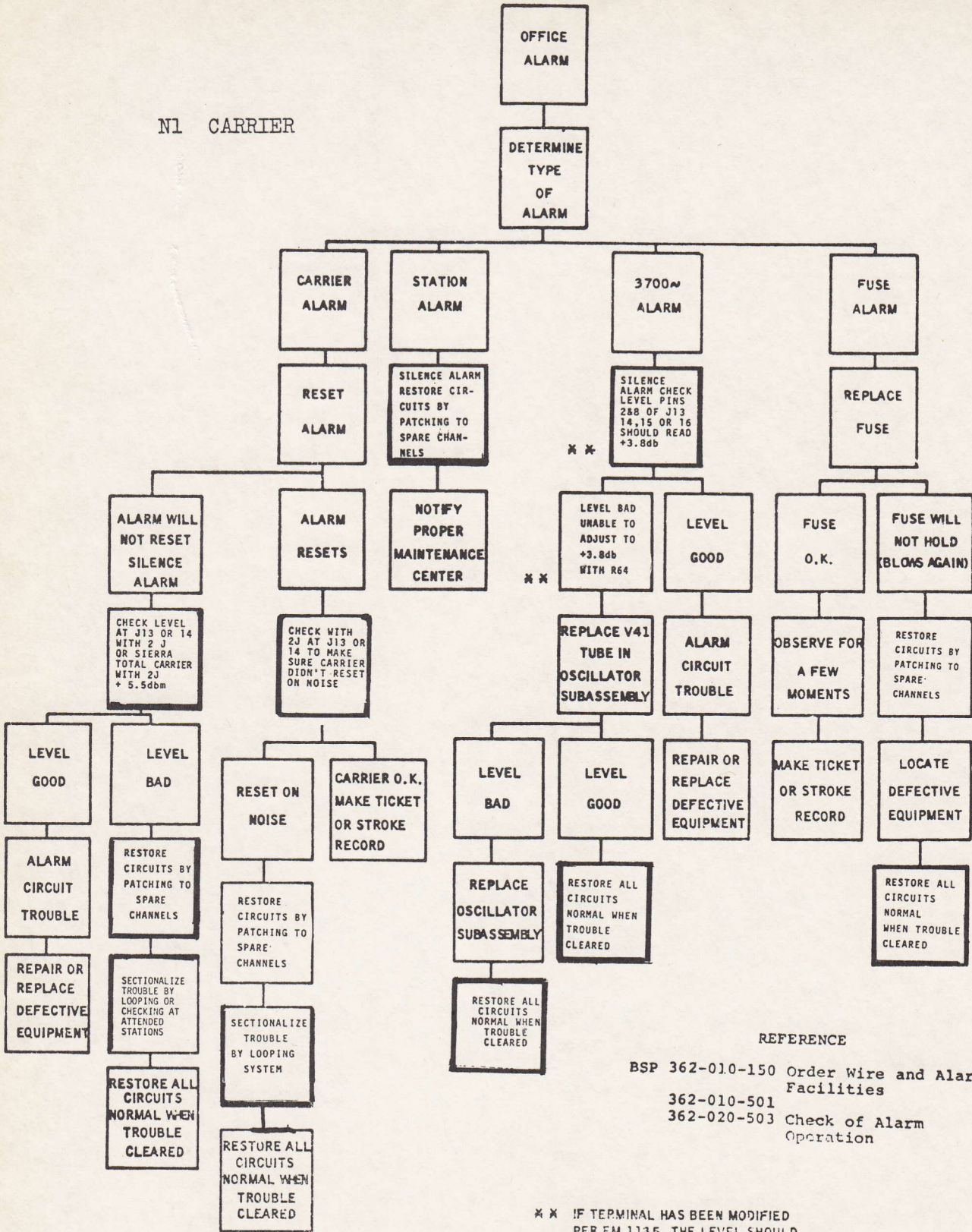

REFERENCE

BSP 362-010-150 Order Wire and Alarm Facilities
 362-010-501
 362-020-503 Check of Alarm Operation

* * IF TERMINAL HAS BEEN MODIFIED PER EM 1135, THE LEVEL SHOULD BE +.8 INSTEAD OF +3.8.

N1 and N2

CARRIER

BSP TEST EQUIPMENT REFERENCE
(Specific to N1 & N2 CXR)

N CARRIER SYSTEM TEST SETS

- 103-467-100 J98705M (5M) Channel Unit Test Stand
- 103-468-100 Carrier Failure Indicator
- 103-471-100 J94002N (2N) Group Unit Switching Set
- 103-472-100 J94002M (2M) Switching Set for N1 or ON Repeaters and N2 Repeaters with N2/N1 Adapters
- 103-473-100 J98703BD (3BD) Switching Set for N1A Repeaters and N2 Repeaters in N2/N1A Adapters.
- 103-474-100 J94002J (2J) Repeater Test Set
- 103-475-100 J94002K (2K) Tube Test Set
- 103-476-100 J94002P (2P) Tube Test Set
- 103-477-100 J98703AF (3AF) Deviation Regulator Test Set

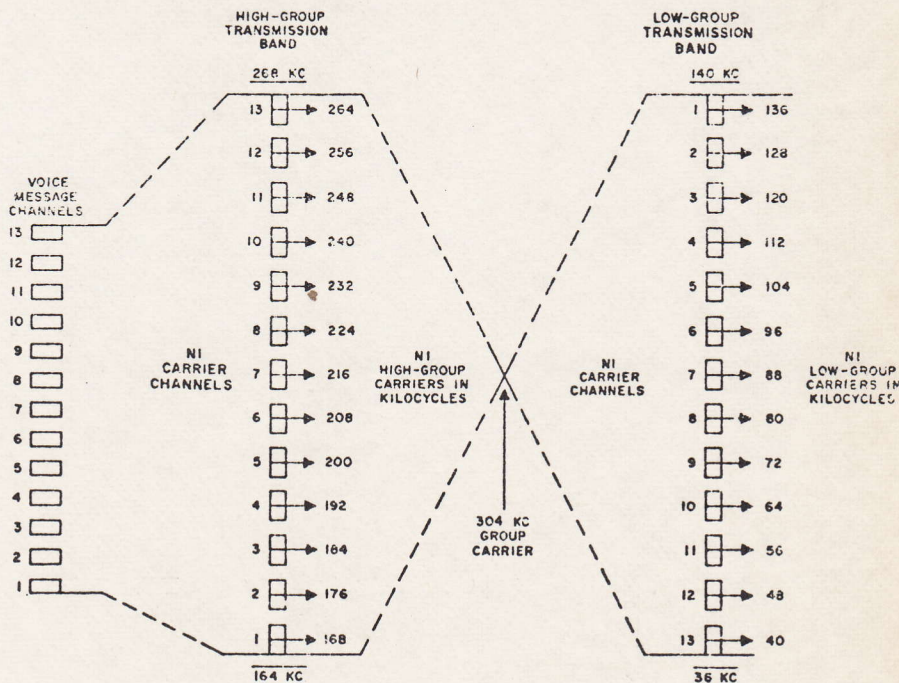

N1 FREQUENCY ALLOCATION

N LINE TEST SETS

- 103-478-100 KS 19750 Deviation Test Set
- 103-478-101 Sierra Model 322A Carrier Generator

N2 SWITCHING SETS

- 103-480-100 & 500 J99272U Switching Set
- 103-480-101 & 501 J99321S Switching Set
- 103-481-100 & 500 J99272W Test Stand
- 103-481-101 & 501 J99272AH Test Stand

NOISE MEASURING SETS

- 103-500-100 J94007A (7A) Range 10 to 552 KHZ
- 103-500-101 N Line Noise Section-alization Set

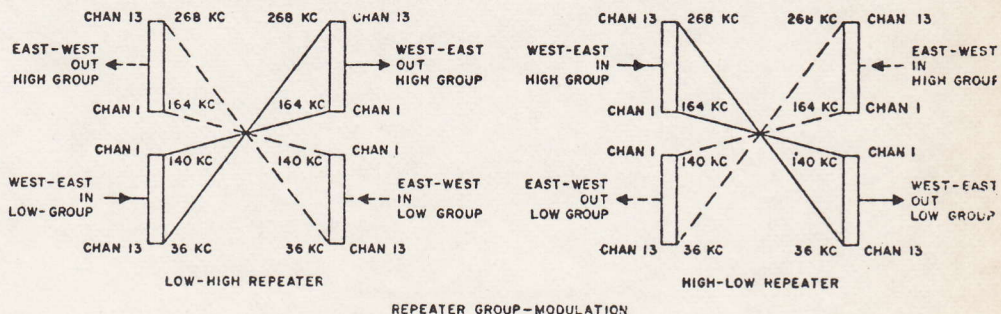
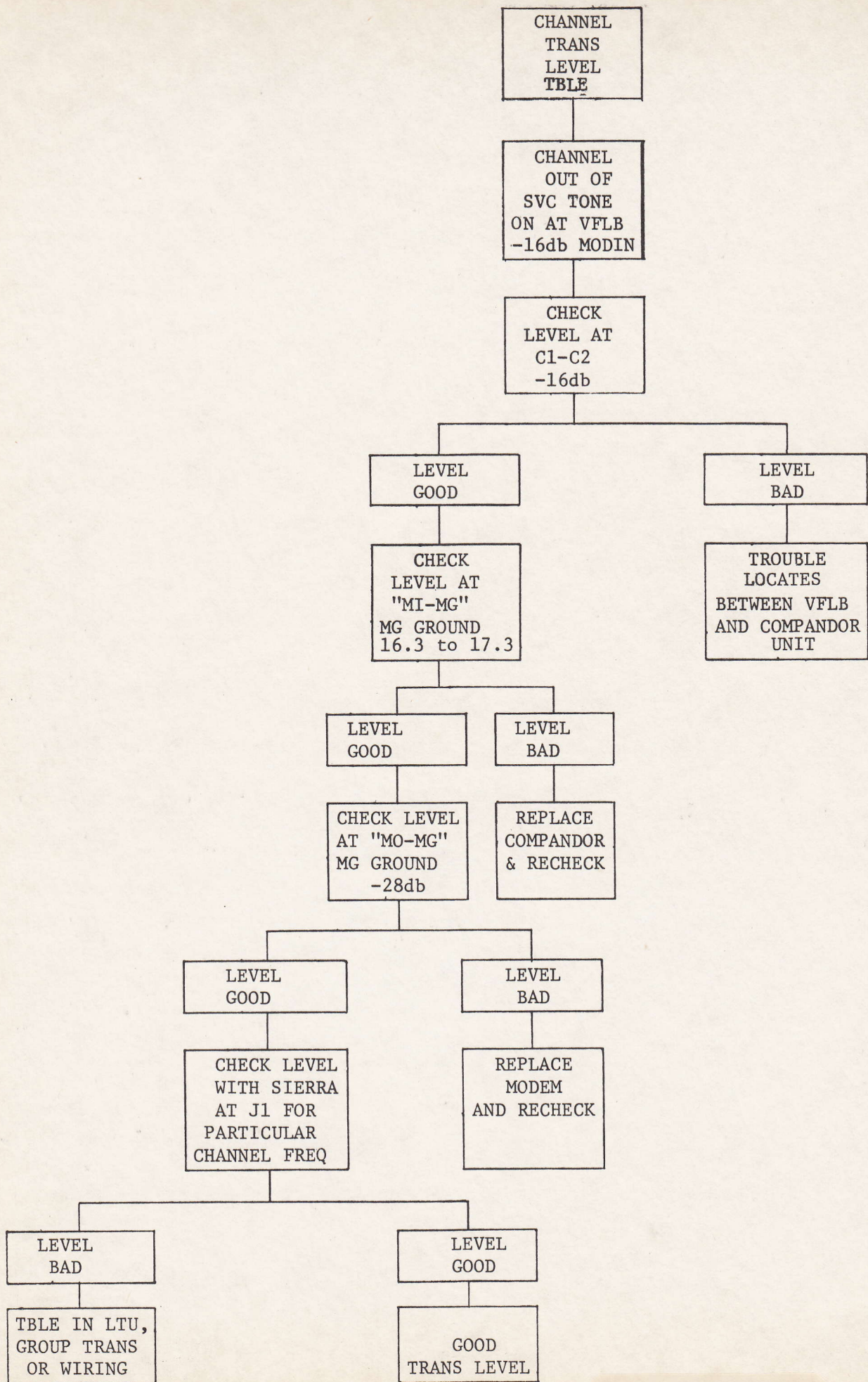

Fig. 2 - N1 Carrier Frequency Allocation and Repeater Group Modulation



CHANNEL
RECEIVE
LEVEL
TROUBLE

CHANNEL OUT
OF SVC. HAVE
DISTANT END
PUT TONE ON
CHANNEL -16db

CHECK LEVEL
AT VFLB
FOR +7db

LEVEL
GOOD
+7db

RECEIVE
LEVEL
OK

RESTORE
TO
SERVICE

LEVEL
BAD ADJUST
"OUTADJ" POT
FOR +7db

UNABLE TO
ADJUST TO
+7db

CHECK
LEVEL AT
"DI-DG"
DG GROUND
-3 TO -22db

ADJUSTED
"OUTADJ" POT
TO +7db

RECEIVE
LEVEL
OK

RESTORE TO
SERVICE

LEVEL
GOOD

CHECK
LEVEL AT
"DO-DG"
DG GROUND
-4 TO -6db

LEVEL
BAD

CHECK LEVEL
AT CABLE
TERM WITH
SIERRA

LEVEL
GOOD

CHECK LEVEL
AT E1 TO E2
+6.8 TO +7.2db
NO ADJ

ADJ "OUTADJ"
POT FOR +7db
AT VFLB

LEVEL
BAD

REPLACE
MODEM
AND
RECHECK

LEVEL
GOOD

BAD GROUP REC.
OR
WIRING
TROUBLE

LEVEL
BAD

TROUBLE
LOCATES
ON LINE

UNABLE TO
ADJUST TO
+7db

REPLACE
COMPANDOR
& RECHECK

ADJUSTED "OUT"
ADJ" POT FOR
+7db REC. LEVEL
GOOD

RESTORE TO SVC.

N2 CARRIER

PACKAGED
AND
NONPACKAGED

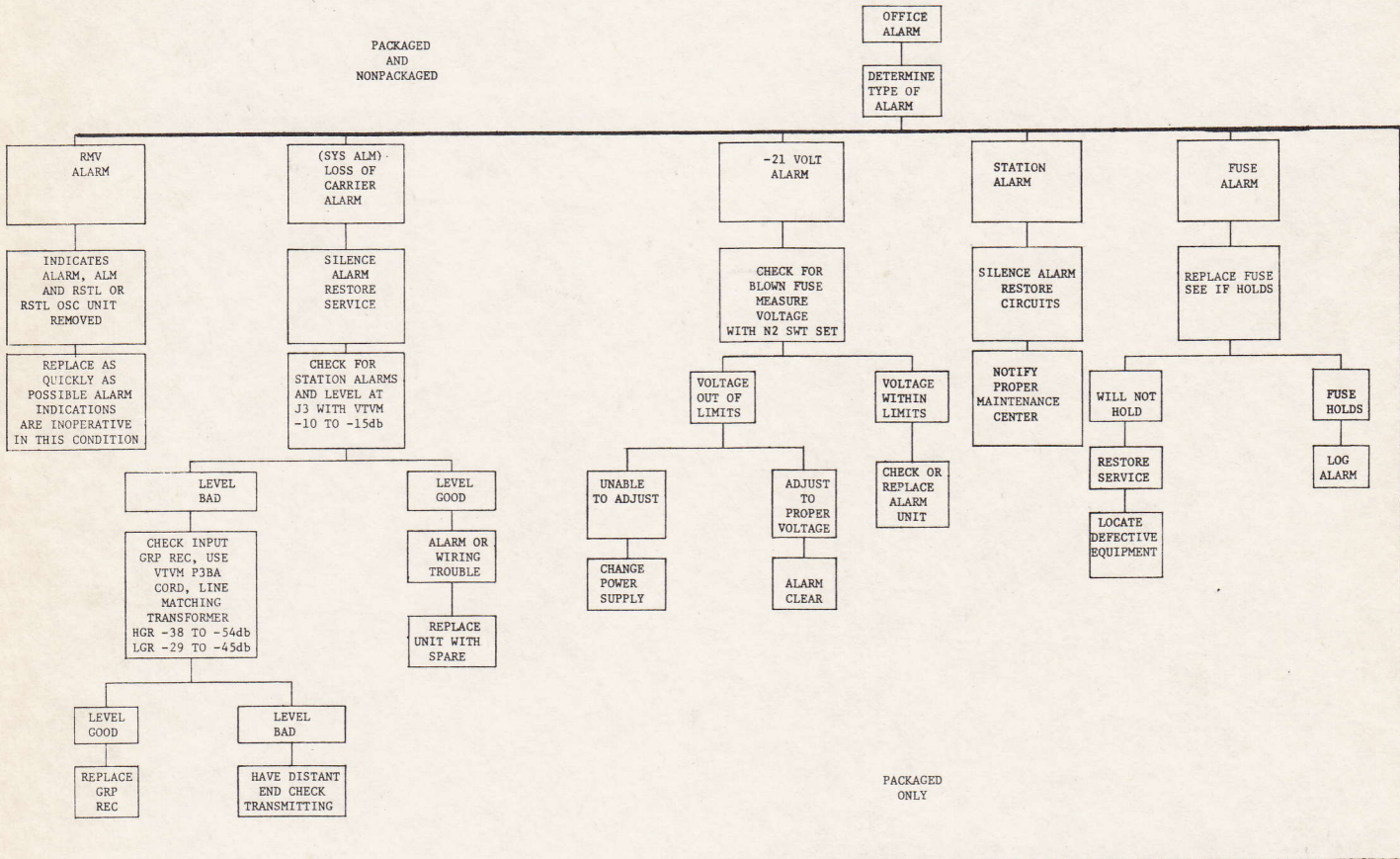

PACKAGED ONLY

REFERENCE

- BSP 362-803-100 thru 511 Alarm Units
- 362-340-100 N2, Group Alarm Unit and Group Alarm Signal Receiver Unit
- 362-340-501 J99272AR Signal Receiver
- 362-345-100 Group Alarm and E-Signaling

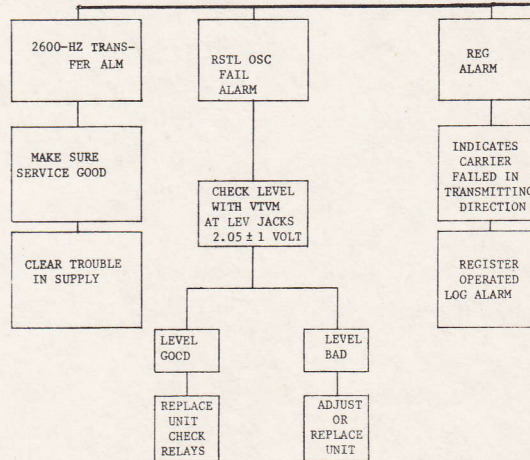

CHART 1

SECTION 362-801-501

CARRIER-FREQUENCY MEASUREMENTS

TESTS/UNITS	JACKS	METER	ADJUST	REQUIREMENT	NOTES	REFERENCE
Transmitted Carrier Channel Modem Output	MO-MG	VTVM	—	-27.5 to -29.5 dB		362-806-501
Total Power Output Group Transmitter	J1	2J	—	+10.0 to +14.0 dBm	HGT	Fully equipped systems only.
				+ 1.0 to + 5.0 dBm	LGT	
Group Transmitter (slope, bulge, cubic, and quartic)	J1	DTS	—	Measured slope ± 1.0 dB of design value. Measured bulge, cubic, and quartic ± 0.5 dB of design value.		362-805-502
Group Transmitter (individual power outputs)	J1	CFVM	—	± 1.0 dB of computed slope.	Adjacent carriers no greater than 1.0-dB level difference.	362-805-502
				Measured slope ± 1.0 dB of design value.		
Total Power Output Group Receiver	J3	VTVM	—	-10.5 to -15.5 dB		362-805-503
Group Receiver (slope, bulge, cubic, and quartic)	J3	DTS	Repeater Line	Measured slope and bulge ± 1.0 dB of design value.		362-805-504
				Measured cubic and quartic ± 0.5 dB of design value.		
Group Receiver (individual power outputs)	J3	CFVM	—	-1.5 dB of computed slope.	Adjacent channels no greater than 1.0-dB level difference.	362-805-504
Received Carrier Channel Modem Input	DI-DG	VTVM	—	-3.0 to -22.0 dB (LC Filter)	Adjacent channels no greater than 5.0-dB level difference.	362-806-501
				-8.5 to -27.5 dB (Crystal Filter)		

VOICE-FREQUENCY MEASUREMENTS
(Send 1000~ at -16 dBm in VF IN or MOD IN)

TEST	UNIT	JACKS	METER	REQUIREMENT	ADJUST	NOTES	REFERENCE
VF IN	Comporand	C1, C2	VTVM	-15.8 to -16.5 dBm	—		362-800-505
	Modem	MI, MG	VTVM	+16.3 to +17.3 dB	—		
VF OUT	Modem	DO, DG	VTVM	- 4.0 to - 6.0 dB	—		362-806-502
VF OUT VF Jacks Used, GAIN ADJ Pot Not Used	Comporand	E1, E2	VTVM	+ 6.8 to + 7.2 dBm	—	May be higher because of office loss to patch bay	362-800-505
	VF Patch Bay	DEMODO OUT	TMS	+7.0 dBm	OUT ADJ		
VF OUT No VF Jacks	Comporand	E1, E2	VTVM	+ 6.8 to + 7.2 dBm	OUT ADJ	Readjust to +7.0 dBm	

TRANSISTOR EMITTER CURRENT TEST

SECTION 362-805-505

Measure the following voltages on both the group transmitting and the group receiving units and check that they fall within the specified limits. Use the 3-volt voltmeter scale whenever possible.

Caution: To assure that the bias voltages are not affected by over-driving the amplifier due to line noise or high signal level, do not make measurements on receiving group units unless carriers have been applied and the unit has regulated to the proper output power.

Requirement: The voltages shall be as follows:

TEST POINTS ON FACE OF GROUP EQUIPMENT	TRANSMITTER		RECEIVER		NOMINAL VOLTAGE volts	VOLTAGE LIMITS
	HIGH GROUP	LOW GROUP	HIGH GROUP	LOW GROUP		
EM1 to --21V	X	X	X	X	2.2	1.9 to 2.5
EM3 to --21V	X	X	X	X	3.0 (Factory Set)	2.6 to 3.6
EM4 to --21V	X		X	X	3.0	2.5 to 3.6
EM5 to --21V		X		X	2.2	1.6 to 3.6
EM6 to --21V		X		X	4.2	3.4 to 5.0

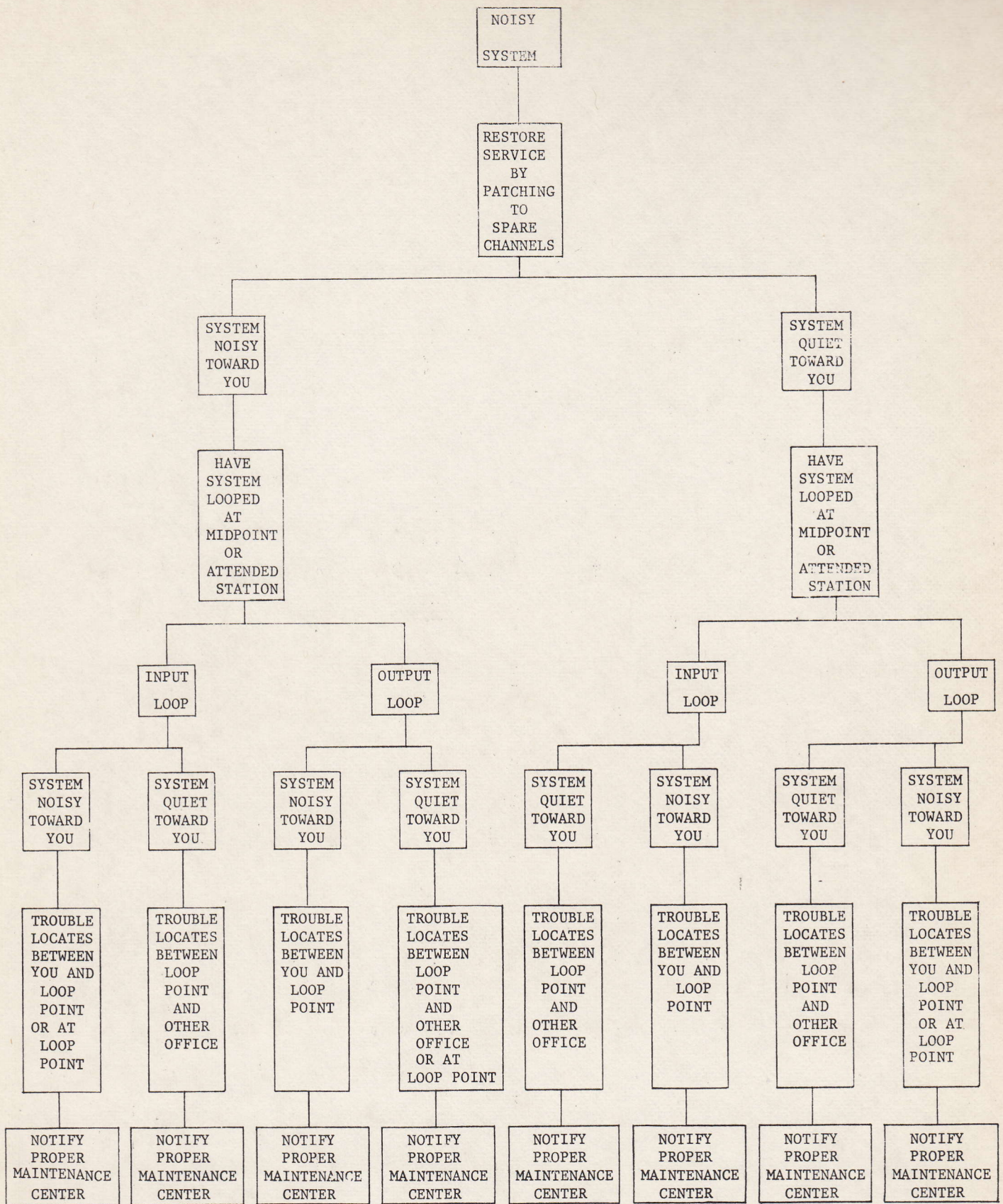

INDEX

1. COVER
2. ACKNOWLEDGEMENTS
3. N1 CXR, INTERNAL POT ADJUSTMENTS
4. N1 CXR, TEST POINTS / TEST LEVELS
5. BLOCK DIAGRAM, N1 CHANNEL UNIT
6. N1 CXR, LINE UP & MAINTENANCE TESTS
7. FLOW CHART - TRANSMITTING LEVEL TROUBLE
8. FLOW CHART - RECEIVING LEVEL TROUBLE
9. N1 CXR, SIGNALING TROUBLE
10. N1 CXR, OPEN SYSTEM - FLOW CHART
11. N1 CXR, OFFICE ALARM - FLOW CHART
12. BSP REF (TEST EQ) & N CXR FREQ ALLOCATIONS
13. N2 CXR, TRANSMITTING LEVEL TROUBLE
14. N2 CXR, RECEIVING LEVEL TROUBLE
15. N2 CXR, OFFICE ALARM - FLOW CHART
16. CARRIER - FREQUENCY MEASUREMENTS
17. VOICE - FREQ. MEAS. & EMITTER CURRENT TEST
18. NOISY SYSTEM, N1 OR N2

INDEX

NOTE: FLOW CHART 18 MAY ALSO BE USED TO
SECTIONALIZE AN N2 OPEN SYSTEM TROUBLE

**NO JOB IS SO IMPORTANT
AND NO SERVICE IS SO URGENT-
THAT WE CANNOT TAKE TIME
TO PERFORM OUR WORK SAFELY.**

BELL SYSTEM